

- OFFICIAL RIDER -

(local or university opening bands welcomed in order to share gear and cut your costs)

- 1) A full [P.A.](#) (see sample link) which would include:
 - 2 main speakers (**preferably > or equal to 200 Watts RMS / 400 Watts Peak Handling**)
 - 1 monitor (speakers) for Lead Singer, 1 more preferable for drummer as well.
 - 2 vocal mics (any make model)
 - Microphone for bass drum (e.g. AKG D112) and snare drum microphone (Shure SM57 or 58) + cables and stands. If large room, mics on the amps.
 - **Powered Mixer** and/or **Mixer+Amplifier** (> 300-400 watts) to power all of these speakers and mic, with cables, (2) 3-pronged extension cords or power strips > 6 ft. **Will be running click track/lpod into Mixer, please make sure this is possible**
- 2) **Stage Area** - full 4-piece drumset: with at least 20-22" bass drum with pedal, 10" or 12" rack tom, 14" or 16" floor tom, snare drum and including adjustable drum throne, snare stand, 4 boom cymbal stands with all nuts and felts, hi-hat stand with clutch, and cymbals (2 crashes, 1 ride, and hi-hats) – unless pre-arranged *(local or university opening bands welcomed in order to share gear and cut your costs)*

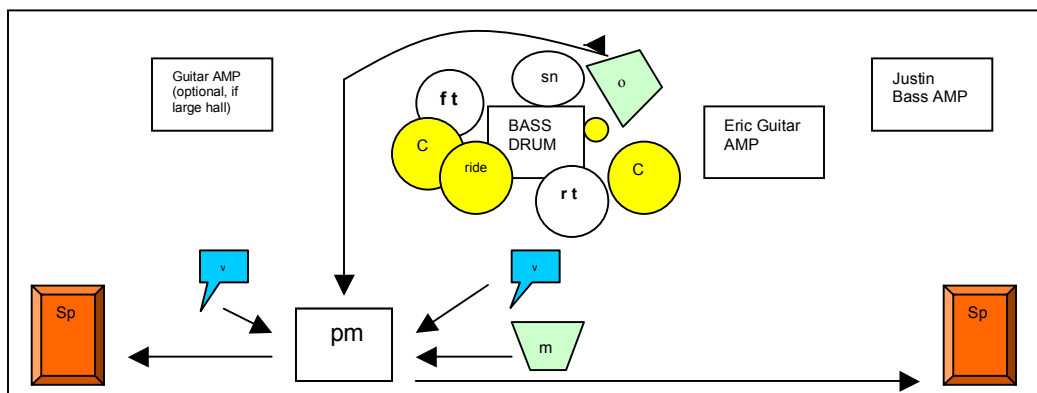

Front of Stage

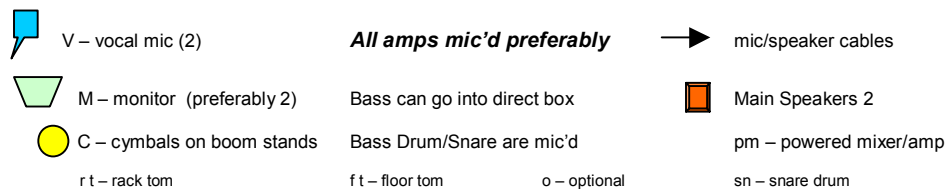

- 3) 1 guitar amp, (2 if large hall, ~75 seats) preferably a tube Fender 65 Twin Reverb. Bass amp any make/model but at least 400 watts.
- 4) Laptop/desktop with DVD capability, or DVD player, into LCD projector, onto any size screen or white background, with appropriate cables. Screen can be anywhere near stage.
- 5) Transport to and from venue if needed.
- 6) Lodging for day before and day of event, if needed

